

Measurement of α_{QED} : an alternative approach

A.Arbuzov D.Haidt C.Matteuzzi M.Paganoni L.T.

CERN-PH-TH/2004-016 - hep-ph/0402211
European Physics Journal C35, 267 (2004)

Karlsruhe, Bhabha Workshop, April 21 2005

We propose a method to determine the running of
 α_{QED}
from the measurement of small-angle Bhabha
scattering

The method is suited to high statistics experiments
at e^+e^- colliders, which are equipped with
luminometers in the appropriate angular region

We present a new simulation code predicting small-
angle Bhabha scattering

The electroweak Standard Model $SU(2) \otimes U(1)$ contains Quantum Electrodynamics QED as a constitutive part.

The running of the electromagnetic coupling

$$\alpha_{\text{QED}}(q^2)$$

is determined by the theory as

$$\alpha_{\text{QED}}(q^2) = \alpha_{\text{QED}}(0) / (1 - \Delta\alpha(q^2))$$

$$\alpha_{\text{QED}}(0) = \alpha_0$$

$$\alpha_0 = \frac{e^2}{2\pi\epsilon_0 hc}$$

is the **Sommerfeld**
“fine structure constant”



$$\Delta\alpha(q^2)$$

Vacuum polarization

$$\Delta\alpha = \Delta\alpha_{lept} + \Delta\alpha_{had}$$

arises from quantum loop contribution to the photon propagator receiving contributions from quarks (hadrons), leptons and gauge bosons

The hadronic contribution is estimated **in the s channel** with a dispersion integral
from the cross-section e+e- to hadrons cross-section

S. Eidelman and F. Jegerlehner: Z. Phys. **C67** (1995) 602

F. Jegerlehner: hep-ph/0308117

M. Davier and A. Höcker: Phys. Lett. **B435** (1998) 427

M. Davier, S. Eidelman, A. Höcker and Z. Zhang: Eur. Phys. J. **C27** (2003) 497

$$\begin{aligned} \Delta\alpha &= \sum_f \text{Diagram} \\ &= \frac{\alpha}{3\pi} \sum_f Q_f^2 N_{cf} \left(\ln \frac{M_Z^2}{m_f^2} - \frac{5}{3} \right) \\ &= \Delta\alpha_{leptons} + \Delta\alpha_{quarks}^{(5)} \end{aligned}$$

$$\alpha(s) = \frac{\alpha}{1 - \Delta\alpha(s)}$$

$$\Delta\alpha(s) = -4\pi\alpha \text{Re} \left[\Pi'_\gamma(s) - \Pi'_\gamma(0) \right] .$$

$$\text{Re}\Pi'_\gamma(\mathbf{s}) - \Pi'_\gamma(0) = \frac{\mathbf{s}}{\pi} \text{Re} \int_{s_0}^{\infty} ds' \frac{\text{Im}\Pi'_\gamma(s')}{s'(s' - \mathbf{s} - i\varepsilon)}$$

and using the optical theorem (unitarity) one has

$$\text{Im}\Pi'_\gamma(\mathbf{s}) = \frac{\mathbf{s}}{e^2} \sigma_{tot}(e^+e^- \rightarrow \gamma^* \rightarrow \text{hadrons})(\mathbf{s}) .$$

In terms of the cross-section ratio

$$R(\mathbf{s}) = \frac{\sigma_{tot}(e^+e^- \rightarrow \gamma^* \rightarrow \text{hadrons})}{\sigma(e^+e^- \rightarrow \gamma^* \rightarrow \mu^+\mu^-)} ,$$

where $\sigma(e^+e^- \rightarrow \gamma^* \rightarrow \mu^+\mu^-) = \frac{4\pi\alpha^2}{3s}$ at tree level, we finally obtain

$$\Delta\alpha_{\text{hadrons}}^{(5)}(M_Z^2) = -\frac{\alpha M_Z^2}{3\pi} \text{Re} \int_{4m_\pi^2}^{\infty} ds \frac{R(\mathbf{s})}{s(s - M_Z^2 - i\varepsilon)} .$$

Here we follow an alternative approach:

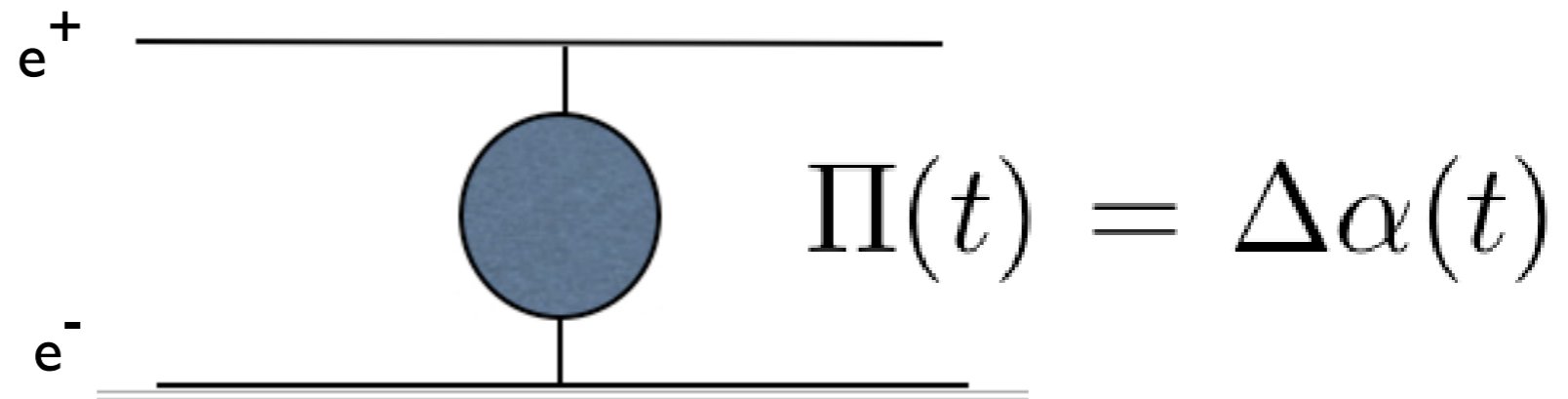

- the running of α is studied using small-angle Bhabha scattering
- This process provides unique information on the QED coupling constant α at low space-like momentum transfer $t = -|q^2|$ in the t channel, with $t = - (1/2)s (1 - \cos \theta)$ for example for

$$\sqrt{s} = 91.1 GeV$$

$$\theta = 30 \text{ mrad} \quad t = 2.2 \text{ GeV}^2$$

$$\theta = 150 \text{ mrad} \quad t = 30 \text{ GeV}^2$$

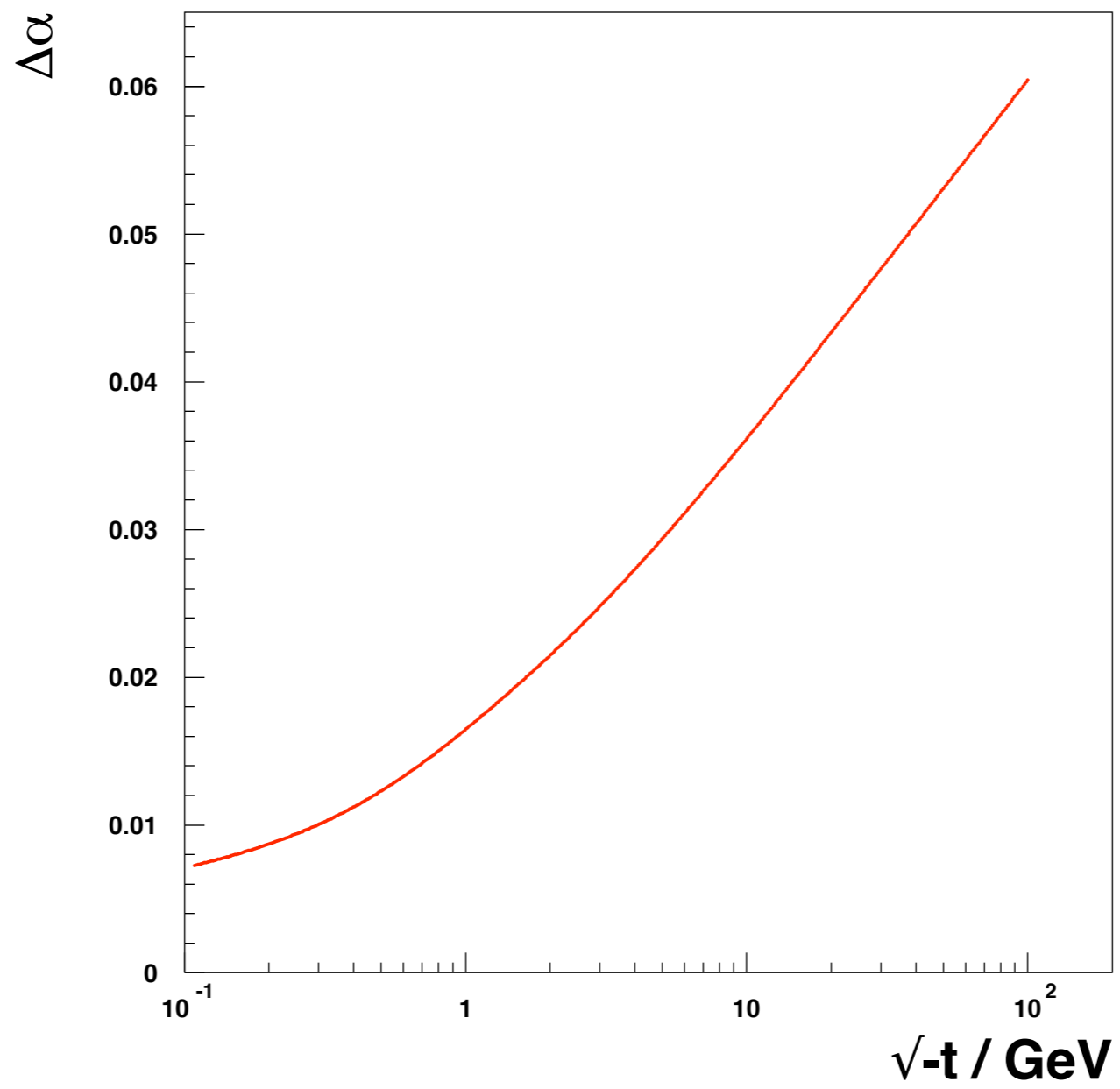

by using *alphaQED* F.Jegerlehner

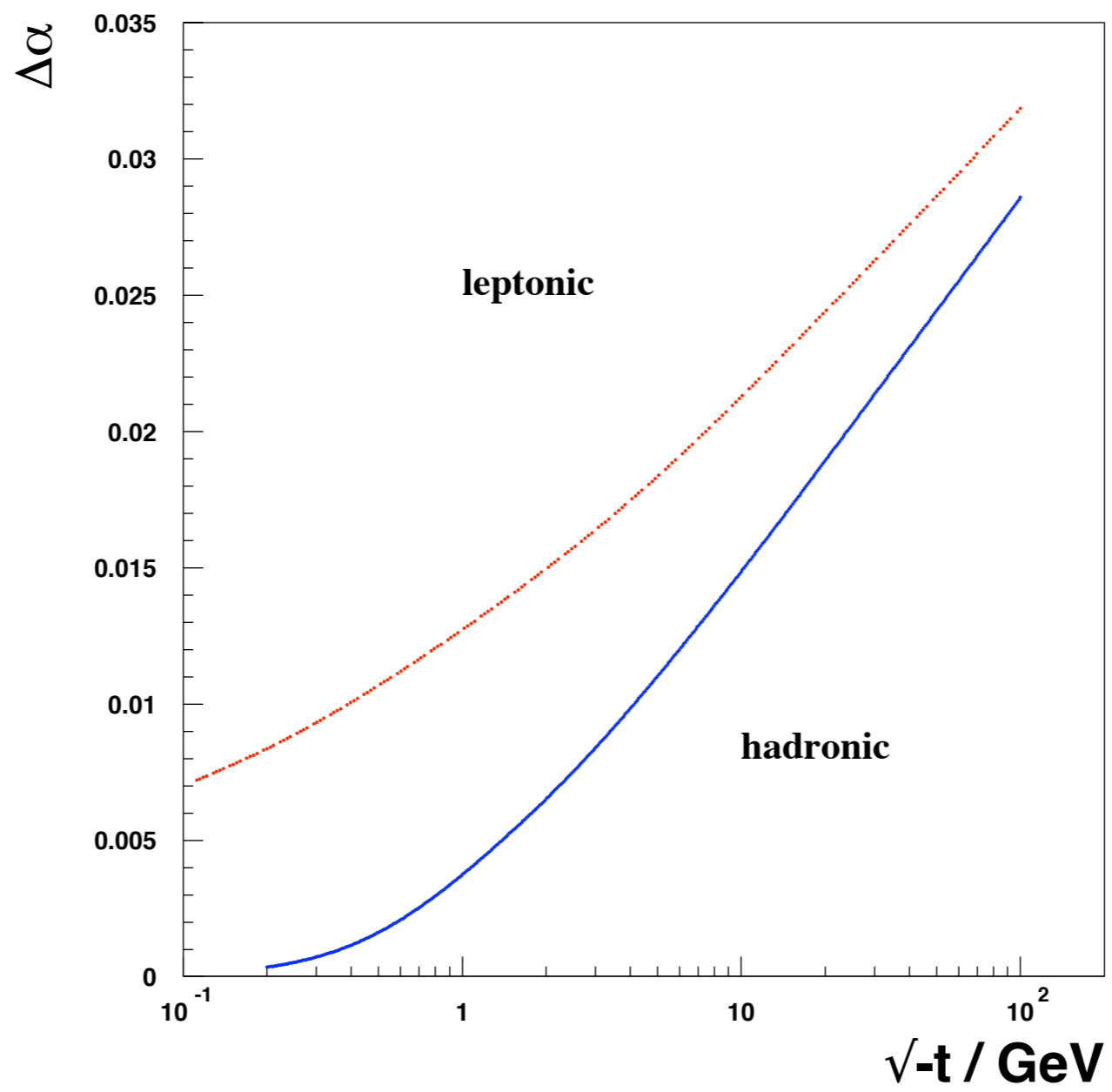

The method to measure the running of α

exploits the fact that the cross section for the process $e^+e^- \rightarrow e^+e^-$ can be conveniently decomposed into three factors:

$$\frac{d\sigma}{dt} = \frac{d\sigma^0}{dt} \left(\frac{\alpha(t)}{\alpha(0)} \right)^2 (1 + \Delta r(t))$$

- The Bhabha Born cross section, including soft and virtual photons is precisely known and accounts for the strongest dependence on t
- The vacuum-polarization effect in the leading photon t -channel exchange is incorporated in the running of α and gives rise to the squared factor
- $\Delta r(t)$ collects all the remaining real (in particular collinear) and virtual radiative effects not incorporated in the running of α
- The experimental data (after correction for detector effects) have to be compared with this distribution

The Luminosity measurement

The precise determination of the luminosity at e^+e^- colliders is a crucial ingredient to obtain an accurate evaluation of all the physically relevant cross sections.

They necessarily have to rely on some reference process, which is usually taken to be the small-angle Bhabha scattering.

Given the high statistical precision provided by the LEP collider, an equally precise knowledge of the theoretical small-angle Bhabha cross section is mandatory. In the 1990's the substantial progress in measuring the luminosity reached by the LEP machine has prompted several groups to make a theoretical effort aiming

at a **0.1%** accuracy.

An even better accuracy can be reached once the complete two-loop Bhabha (including order α constants) cross-section will be computed

This goal has indeed been achieved by developing a dedicated strategy.

For the first time small-angle Bhabha scattering was evaluated analytically, following a new calculation technique that yields the required precision

Arbuzov, Fadin, Lipatov, Merenkov, Kuraev, T. (1995)
Nucl. Phys. B485(1997)457

Analytical calculations have been combined with Monte Carlo programs in order to simulate realistically the conditions of the LEP experiments

LABSMC

NLLBHA

SAMBHA

BHLUMI

The cross section $d\sigma^0/dt$

$$\frac{d\sigma^0}{dt} = \frac{d\sigma^B}{dt} \left(\frac{\alpha(0)}{\alpha(t)} \right)^2$$

$$\frac{d\sigma^B}{dt} = \frac{\pi\alpha_0^2}{2s^2} \text{Re}\{B_t + B_s + B_i\},$$

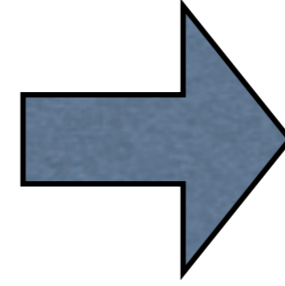

$$\Pi(t) = \Delta\alpha(t)$$

$$B_t = \left(\frac{s}{t}\right)^2 \left\{ \frac{5 + 2c + c^2}{(1 - \Pi(t))^2} + \xi \frac{2(g_v^2 + g_a^2)(5 + 2c + c^2)}{(1 - \Pi(t))} \right.$$

$$\left. + \xi^2 \left(4(g_v^2 + g_a^2)^2 + (1 + c)^2(g_v^4 + g_a^4 + 6g_v^2g_a^2) \right) \right\}$$

$$B_s = \frac{2(1 + c^2)}{|1 - \Pi(s)|^2} + 2\chi \frac{(1 - c)^2(g_v^2 - g_a^2) + (1 + c)^2(g_v^2 + g_a^2)}{1 - \Pi(s)}$$

$$+ \chi^2 [(1 - c)^2(g_v^2 - g_a^2)^2 + (1 + c)^2(g_v^4 + g_a^4 + 6g_v^2g_a^2)]$$

$$B_i = 2\frac{s}{t}(1 + c)^2 \left\{ \frac{1}{(1 - \Pi(t))(1 - \Pi(s))} \right.$$

$$+ (g_v^2 + g_a^2) \left(\frac{\xi}{1 - \Pi(s)} + \frac{\chi}{1 - \Pi(t)} \right)$$

$$\left. + (g_v^4 + 6g_v^2g_a^2 + g_a^4)\xi\chi \right\}$$

$$\chi = \frac{s}{s - m_Z^2 + im_Z\Gamma_Z} \cdot \frac{1}{\sin 2\theta_w}$$

$$\xi = \frac{t}{t - m_Z^2} \cdot \frac{1}{\sin 2\theta_w},$$

$$g_a = -\frac{1}{2}, \quad g_v = -\frac{1}{2} + 2\sin^2\theta_w,$$

$$t = (p_1 - q_1)^2 = -\frac{1}{2}s(1 - c),$$

$$c = \cos\theta, \quad \theta = \widehat{\mathbf{p}_1\mathbf{q}_1}.$$

The running of α

$$\Pi(t) = \Delta\alpha(t)$$

$$\begin{aligned}\Pi(t) &= \frac{\alpha_0}{\pi} \left(\delta_t + \frac{1}{3}L - \frac{5}{9} \right) \\ &+ \left(\frac{\alpha_0}{\pi} \right)^2 \left(\frac{1}{4}L + \zeta(3) - \frac{5}{24} \right) \\ &+ \left(\frac{\alpha_0}{\pi} \right)^3 \Pi^{(3)}(t) + \mathcal{O}\left(\frac{m_e^2}{t}\right),\end{aligned}$$

$$L = \ln \frac{Q^2}{m_e^2}, \quad Q^2 = -t, \quad \zeta(3) = 1.202$$

The radiative factor $1 + \Delta r(t)$ and neglected terms

For the present investigation of the small-angle Bhabha cross section only the correction consistently needed to maintain the required accuracy are kept

All these corrections are included in the new code **SAMBHA**

All the following contributions have been proved to be negligible and are dropped:

- Any electroweak effect beyond the tree level, for instance appearing in boxes or vertices with Z^0 and W bosons, running weak coupling, etc.
 - Box diagrams at order α^2 and larger
- Contributions of order α^2 without large logarithms, leading from order α^4 (i.e. $\alpha^4 L^4$) and subleading higher order ($\alpha^3 L^2$, $\alpha^4 L^3$, ...)
 - Contributions from pair-produced hadrons, muons, taus and the corresponding virtual pair corrections to the vertices (estimated to be of the order of 0.5×10^{-4})





\sqrt{s} (GeV)	91.187	91.2	189	206	500	1000	3000
	45 mrad < θ < 110 mrad						
$\sqrt{\langle -t \rangle}$ (GeV)	3.4	3.4	7.1	7.7	18.8	37.5	112.6
QED	51.428	51.413	11.971	10.077	1.7105	0.42763	0.047514
QED _{<i>t</i>}	51.484	51.469	11.984	10.088	1.7124	0.42809	0.047566
EW	51.436	51.413	11.965	10.072	1.7105	0.42871	0.049507
EW+VP _{<i>t</i>}	54.041	54.018	12.743	10.745	1.8590	0.47303	0.055748
EW+VP	54.036	54.013	12.742	10.744	1.8588	0.47296	0.055742
	5 mrad < θ < 50 mrad						
$\sqrt{\langle -t \rangle}$ (GeV)	1.1	1.1	2.2	2.4	5.8	11.6	34.8
QED	4963.4	4962.0	1155.4	972.54	165.08	41.271	4.5857
QED _{<i>t</i>}	4963.5	4962.1	1155.4	972.57	165.09	41.272	4.5858
EW	4963.4	4962.0	1155.4	972.53	165.08	41.272	4.5885
EW+VP _{<i>t</i>}	5075.0	5073.5	1190.6	1003.3	172.51	43.647	4.9603
EW+VP	5075.0	5073.5	1190.6	1003.3	172.51	43.646	4.9605

Table 1: Various cross sections in nb as a function of the centre-of-mass energy in GeV integrated over the two angular ranges 45–110 mrad and 5–50 mrad. The index *t* denotes the contribution of the corresponding *t* channel Feynman diagrams alone. The last columns are of interest for Future Linear Colliders.

Future Linear Collider

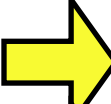
Monte Carlo codes and comparison The new code SAMBHA

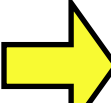
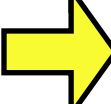
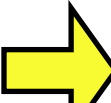
The program LABSMC, which was intended to describe large-angle Bhabha scattering at high energies, has been complemented with a set of routines from NLLBHA so as to be applicable to small-angle Bhabha scattering. This implied the insertion of the relevant second-order next-to-leading radiative corrections ($\mathcal{O}(\alpha^2 L)$) in the Monte Carlo code¹, which are crucial to achieve the per mille accuracy. The extension to cover small angles resulted in the new code **SAMBHA** containing the previously existing features together with the following new characteristics :

-  • the complete electroweak matrix element at the Born level;
-  • the complete set of $\mathcal{O}(\alpha)$ QED radiative corrections (including radiation from amplitudes with Z -boson exchange);
-  • vacuum-polarization corrections by leptons, hadrons [19], and W -bosons;
-  • 1-loop electroweak radiative corrections and effective EW couplings by means of the DIZET v.6.30 [24] package; [24] D.Y. Bardin, M.S. Bilenkii, T. Riemann, M. Sachwitz and H. Vogt:
Comput. Phys. Commun. **59** (1990) 303
-  • higher-order leading-logarithm photonic corrections by means of the electron structure functions [25, 26, 27, 28];
-  • light pair corrections in the $\mathcal{O}(\alpha^2 L^2)$ leading-logarithm approximation including (optionally) the two-photon and singlet mechanisms.

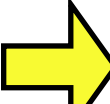
 The code is applicable with the following restrictions:

- a) $E_{\text{beam}} \gg m_e$: the energy has to be much larger than the electron mass;
- b) $m_e/E_{\text{beam}} \ll \theta$: extremely small angles are not described well, but the condition is fulfilled in practice for both small- and large-angle Bhabha measurements in the experiments at LEP, SLC and NLC;
- c) starting from the second order in α , real photon emission is integrated over, i.e. events with two photons separated from electrons are not generated.

Comparison of SAMBHA with BHLUMI

BHLUMI is compared with SAMBHA for integral and,
for the first time
also
differential distributions

The actual measurements are of calorimetric type
Therefore, event samples are generated with both programs, subjecting each event to a
common set of calorimeter-like criteria (CALO)

$$\rho(t) = (d\sigma_{\text{sambha}}/dt - d\sigma_{\text{bhlumi}}/dt) / d\sigma_{\text{bhlumi}}/dt$$

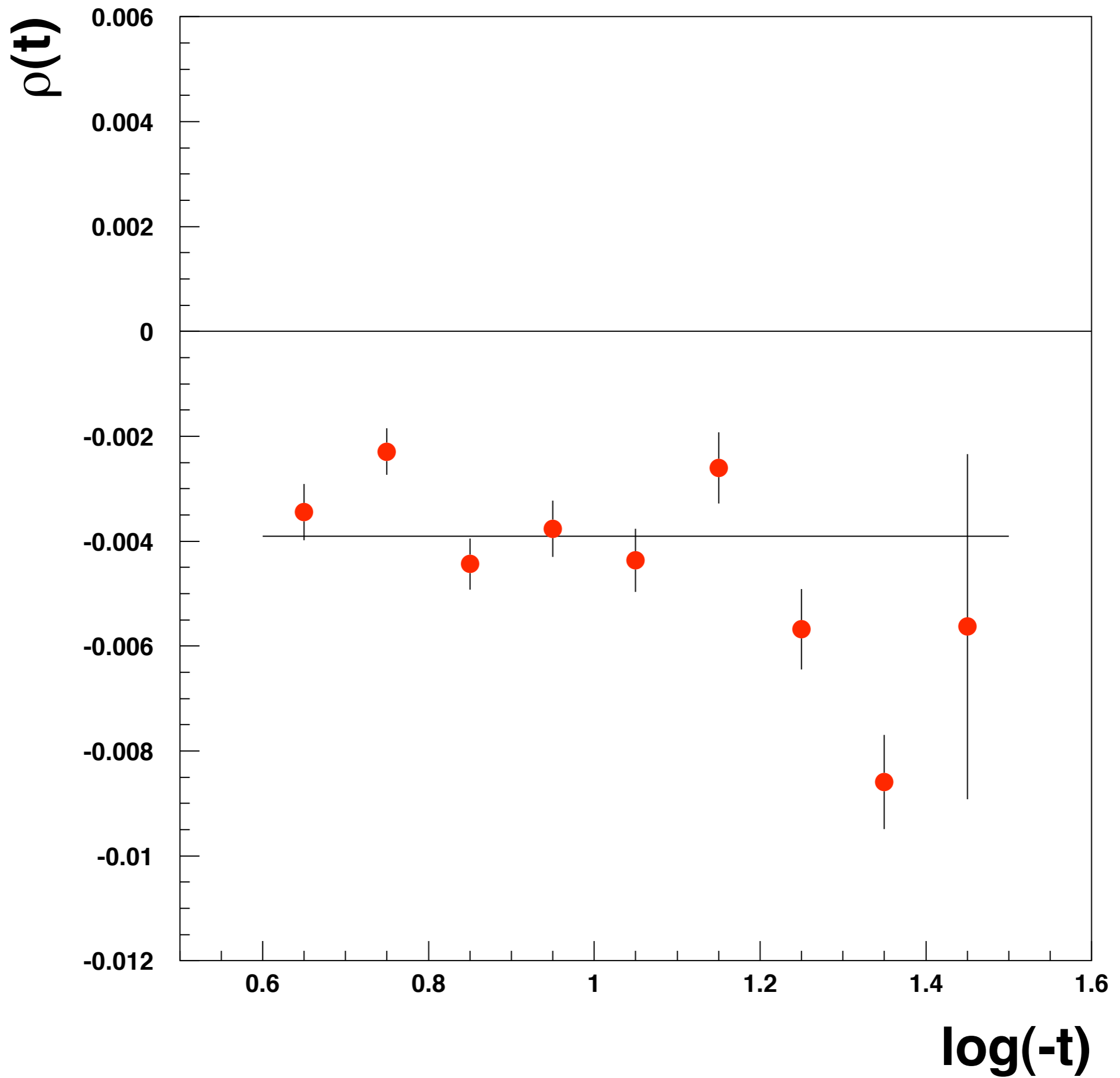

Calorimetric type measurement

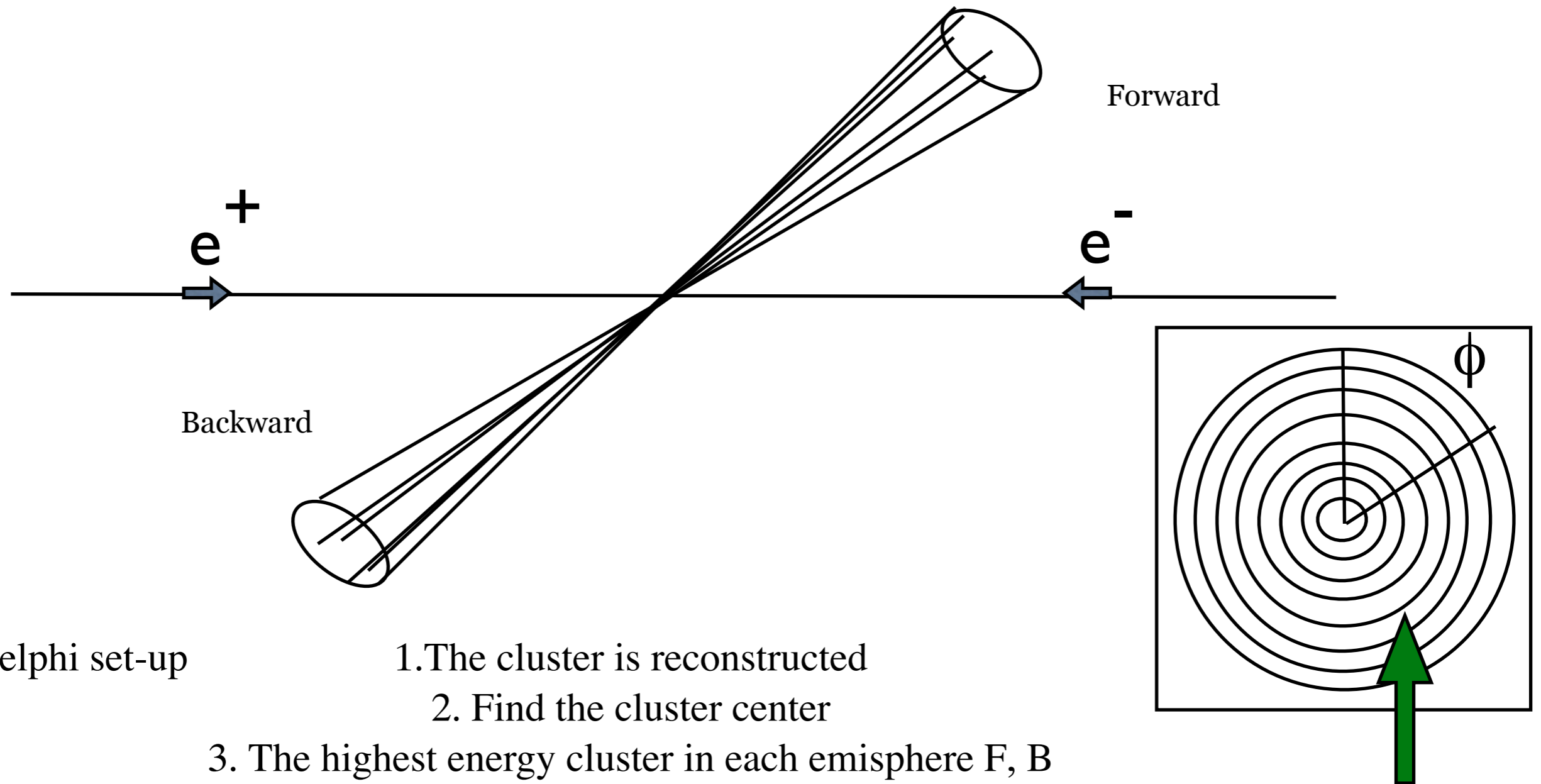

Delphi set-up

1. The cluster is reconstructed

2. Find the cluster center

3. The highest energy cluster in each hemisphere F, B

4. Energy Cuts (suppresses the Initial State Radiation) $\min(E_F, E_B) > 0.65 E_{\text{beam}}$

$\text{Max}(E_F, E_B) > 0.95 E_{\text{beam}}$

5. Take the angle of the center of the most energetic cluster: this defines θ

6. Repeat this procedure for several “rings” segmented detector to reproduce the differential distribution

Comparison and evaluation

Table 3: Numbers of events generated with BHLUMI

$\sqrt{s}(\text{GeV})$	91.2	189	200
$\int \mathcal{L} dt (\text{pb}^{-1})$	75	150	200
Ring 2	1844850	863571	1028210
Ring 3	907754	425586	506131
Ring 4	513696	240550	286994
Ring 5	313218	146731	174740
Ring 6	201893	94033	112168

$$\sigma_i = \sigma_i^0 \left(\frac{\alpha(t_i)}{\alpha(0)} \right)^2 (1 + \Delta r_i),$$

$$\begin{aligned} \sigma_i &= \int^{R_i} dt \frac{d\sigma}{dt} \\ \sigma_i^0 &= \int^{R_i} dt \frac{d\sigma^0}{dt} \\ \left(\frac{\alpha(t_i)}{\alpha(0)} \right)^2 &= \int^{R_i} \frac{dt}{t_{\max} - t_{\min}} \left(\frac{\alpha(t)}{\alpha(0)} \right)^2, \\ 1 + \Delta r_i &= \left(\frac{\alpha(0)}{\alpha(t_i)} \right)^2 \frac{\sigma_i}{\sigma_i^0} \end{aligned}$$

$$\left(\frac{\alpha(t_i)}{\alpha(0)} \right)^2 = \frac{N_i}{\sigma_i^0 \int \mathcal{L} dt} \frac{1}{1 + \Delta r_i},$$

$$\left(\frac{\alpha(t)}{\alpha(0)} \right)^2 = (u_0 \pm \delta u_0) + (u_1 \pm \delta u_1) \cdot \log \frac{-t}{\langle -t \rangle}$$

Table 4: Theoretical predictions for each ring of the three factors of eq. 7. For the conditions defined in sect. 5.1 the angular boundary of ring i is $\theta_i = \arctan(7+3(i-1))/220$.

No. of ring	1	2	3	4	5	6	7
$\sqrt{s} = 91.2 \text{ GeV}$							
σ_i^0	63.077	24.728	12.170	6.8694	4.2517	2.8120	1.9552
$\left(\frac{\alpha(t_i)}{\alpha(0)}\right)^2$	1.0425	1.0475	1.0516	1.0551	1.0582	1.0609	1.0634
$1 + \Delta r_i$	0.9426	0.9440	0.9412	0.9395	0.9240	0.8915	0.7982
$\sqrt{s} = 189 \text{ GeV}$							
σ_i^0	14.685	5.7563	2.8324	1.5984	0.9889	0.6537	0.4542
$\left(\frac{\alpha(t_i)}{\alpha(0)}\right)^2$	1.0554	1.0613	1.0661	1.0702	1.0736	1.0767	1.0794
$1 + \Delta r_i$	0.9377	0.9390	0.9360	0.9329	0.9165	0.8858	0.7898
$\sqrt{s} = 200 \text{ GeV}$							
σ_i^0	13.115	5.1406	2.5295	1.4274	0.8831	0.5838	0.4057
$\left(\frac{\alpha(t_i)}{\alpha(0)}\right)^2$	1.0565	1.0625	1.0673	1.0714	1.0749	1.0780	1.0807
$1 + \Delta r_i$	0.9376	0.9387	0.9352	0.9330	0.9158	0.8847	0.7896
$\sqrt{s} = 1000 \text{ GeV}$							
σ_i^0	0.5248	0.2059	0.1014	0.0573	0.0356	0.0236	0.0165
$\left(\frac{\alpha(t_i)}{\alpha(0)}\right)^2$	1.0921	1.0994	1.1050	1.1096	1.1135	1.1169	1.1199
$1 + \Delta r_i$	0.8622	0.8620	0.8590	0.8545	0.8398	0.8084	0.7205
$\sqrt{s} = 3000 \text{ GeV}$							
σ_i^0	0.0590	0.0234	0.0117	0.0067	0.0042	0.0028	0.0020
$\left(\frac{\alpha(t_i)}{\alpha(0)}\right)^2$	1.1192	1.1267	1.1325	1.1373	1.1414	1.1448	1.1479
$1 + \Delta r_i$	0.8467	0.8457	0.8422	0.8381	0.8253	0.7956	0.6975

Final formula:

$$\left(\frac{\alpha(t_i)}{\alpha(0)} \right)^2 = \frac{N_i}{\sigma_i^0 \int \mathcal{L} dt} \frac{1}{1 + \Delta r_i},$$

Which can be transformed in a linear fit defining the t dependence of α :

$$\left(\frac{\alpha(t)}{\alpha(0)} \right)^2 = (u_0 \pm \delta u_0) + (u_1 \pm \delta u_1) \cdot \log \frac{-t}{\langle -t \rangle}$$

Table 5: Table of fit results; the uncertainties δu_0 and δu_1 are uncorrelated.

\sqrt{s}	91.2 GeV	189 GeV	200 GeV
u_0	1.0573 ± 0.0005	1.0698 ± 0.0008	1.0703 ± 0.0007
u_1	0.0242 ± 0.0028	0.0284 ± 0.0041	0.0318 ± 0.0038
$\langle -t \rangle$	8.5 GeV ²	36.6 GeV ²	40.9 GeV ²

$$\int \mathcal{L} dt = \frac{n_0}{1 + 2\Delta\alpha(\langle t \rangle)} \quad \frac{\delta n_0}{n_0} = 10^{-3} \quad \text{statistical precision}$$

More formulae:

$$n_0 = \int \mathcal{L} dt \cdot \left(1 + 2\Delta\alpha(\langle t \rangle) \right)$$

$$n_1 = \int \mathcal{L} dt \cdot \left(\frac{d}{d \log(-t)} 2\Delta\alpha(t) \right).$$

$$\vdots n_i = u_i \cdot \int \mathcal{L} dt$$

$$\frac{d}{d \log(-t)} \Delta\alpha = \frac{n_1}{2n_0} \left(1 + 2\Delta\alpha(\langle t \rangle) \right)$$

Linear Collider

Let us consider the case of a e^+e^- collider with $E_{\text{c.m.}}$ from 500 to 1000 GeV

The acceptance angles for the Luminosity determination are:

$$1.8^\circ < \theta < 7.2^\circ$$

The min and Max values for $t = -Q^2$
can be readily estimated

■ $Q^{*2min}(GeV^{*2})$ ■ $Q^{*2MAX}(GeV^{*2})$

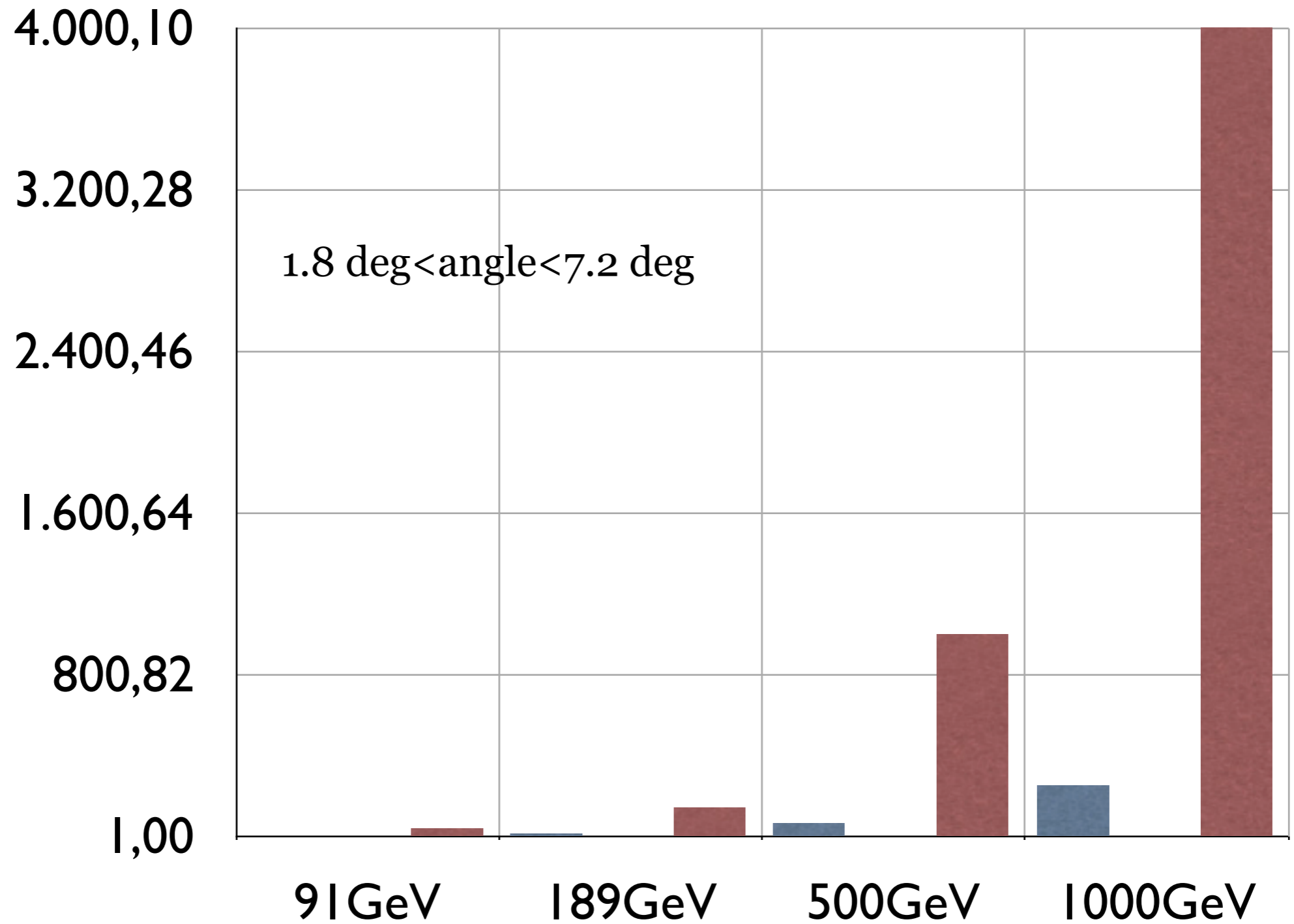

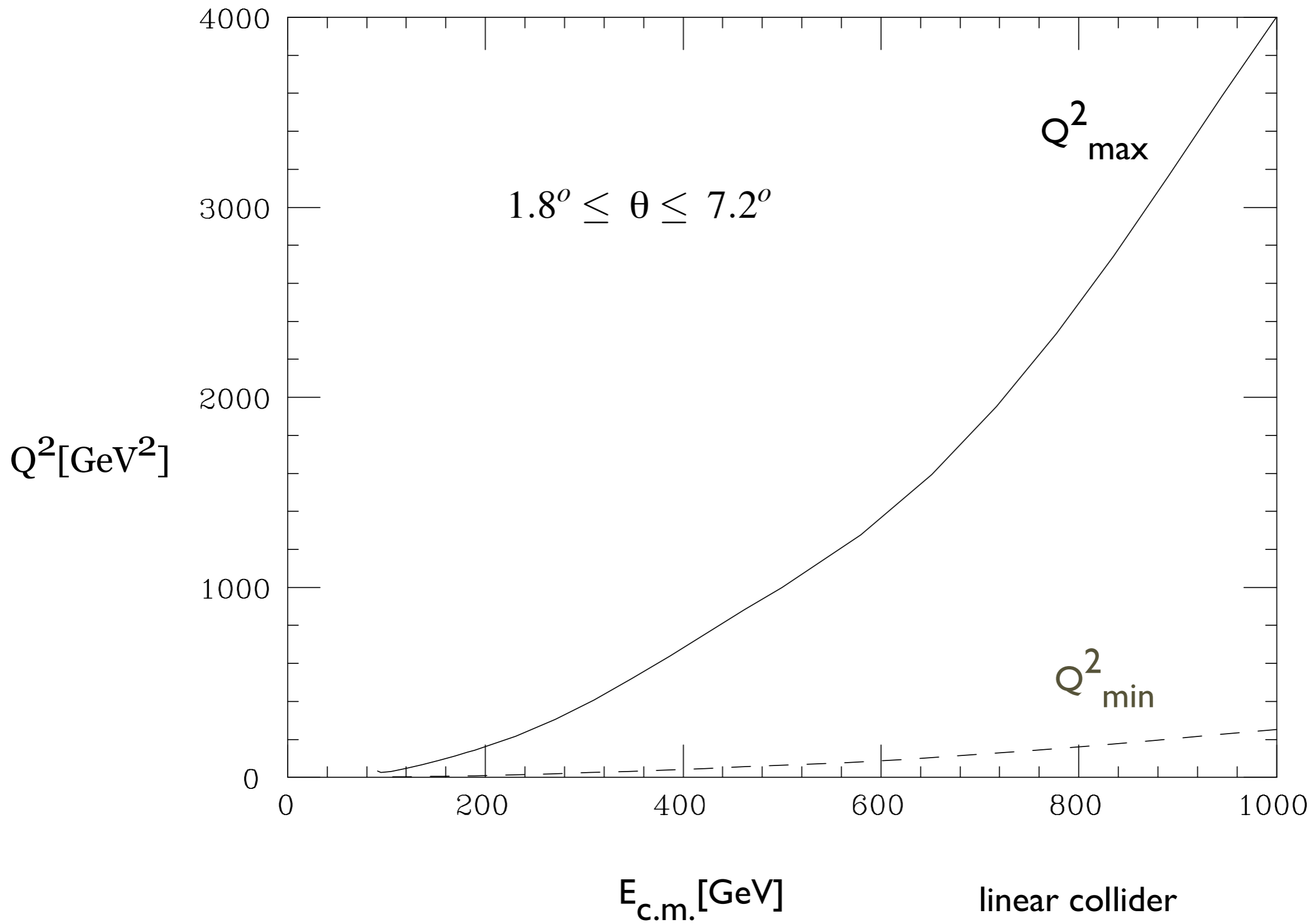

Q^{**2}
[GeV**2]

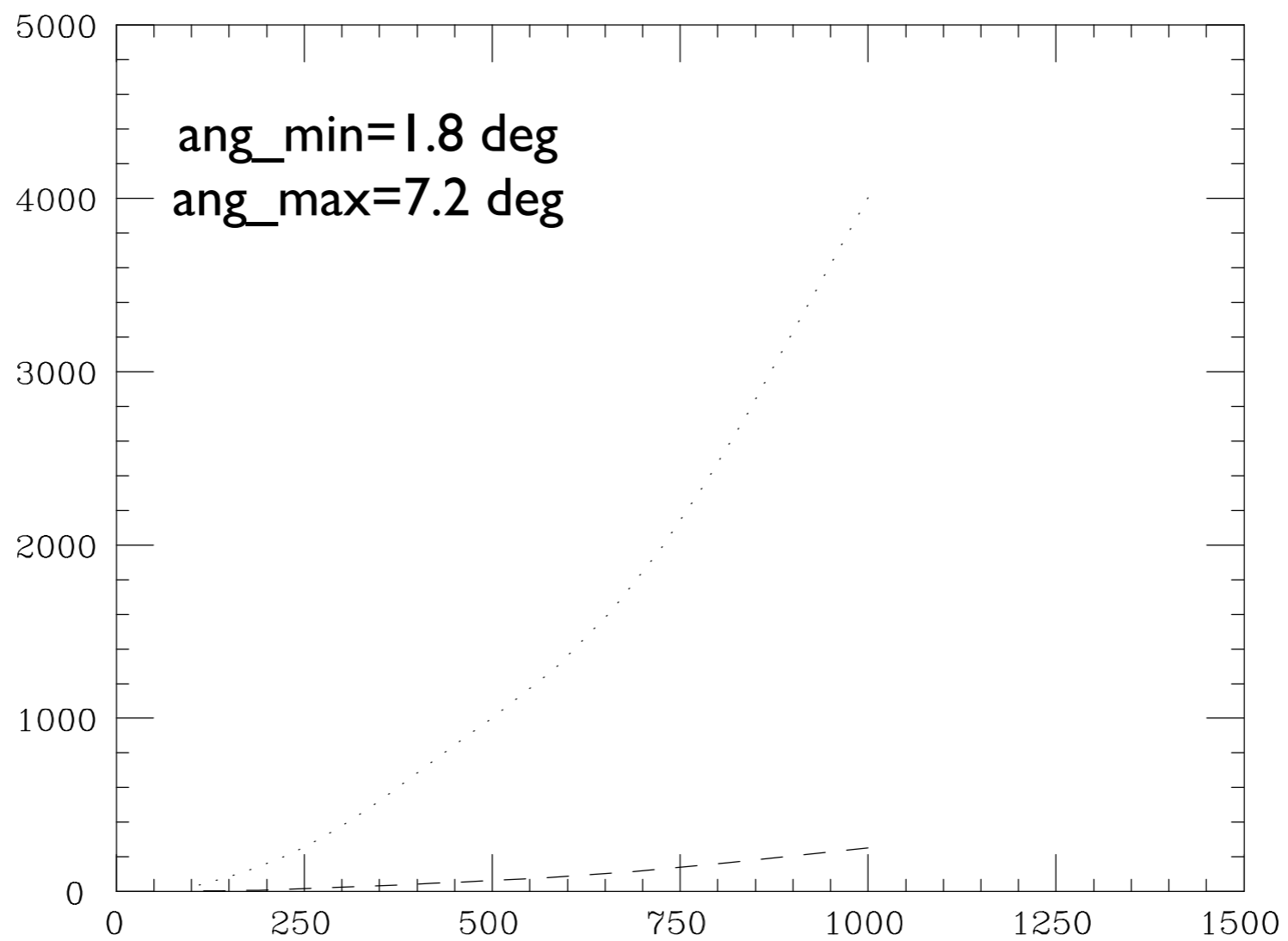

E_{CM} [GeV]

Measurement of the running of the QED coupling in small-angle Bhabha scattering at LEP

OPAL Collaboration

Abstract

Using the OPAL detector at LEP, the running of the effective QED coupling $\alpha(t)$ is measured for space-like momentum transfer through its effect on the angular spectrum of small-angle Bhabha scattering. In an almost ideal QED framework, with very favourable experimental conditions, we obtain:

$$\Delta\alpha(-6.07 \text{ GeV}^2) - \Delta\alpha(-1.81 \text{ GeV}^2) = (440 \pm 58 \pm 43 \pm 30) \times 10^{-5},$$

where the first error is statistical, the second is the experimental systematic and the third is the theoretical uncertainty. This is the strongest direct evidence ever presented that the running of α is consistent with Standard Model expectations. The null hypothesis that α remains constant within the above interval of $-t$ is excluded with a significance above 5σ . Similarly, our results are inconsistent at the level of 3σ with the hypothesis that only leptonic loops contribute to the running, and therefore provide the first clear experimental evidence that hadronic loops also contribute.

Small-angle Bhabha scattering

an almost pure QED process. Differential cross section can be written as:

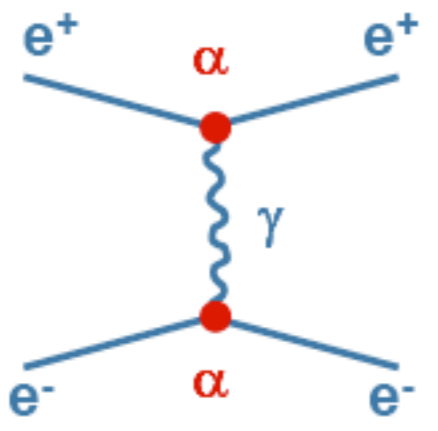

$$\frac{d\sigma}{dt} = \frac{d\sigma^{(0)}}{dt} \left[\frac{\alpha(t)}{\alpha_0} \right]^2 (1 + \varepsilon)(1 + \delta_\gamma) + \delta_Z$$

Born term for t-channel single γ exchange
 $\frac{d\sigma^{(0)}}{dt} = \frac{4\pi\alpha_0^2}{t^2}$
 $\alpha_0 \equiv 1/137.036$

Effective coupling factorized
 $\left(\frac{1}{1 - \Delta\alpha(t)} \right)^2$

Photonic radiative corrections
 $\delta_Z, \delta_\gamma \ll \varepsilon$

Z interference correction
s-channel γ exchange correction

experimentally: high data statistics, very high purity

This process and method advocated by Arbuzov et al., Eur.Phys.J.C 34(2004)267

Small-angle Bhabha scattering in OPAL

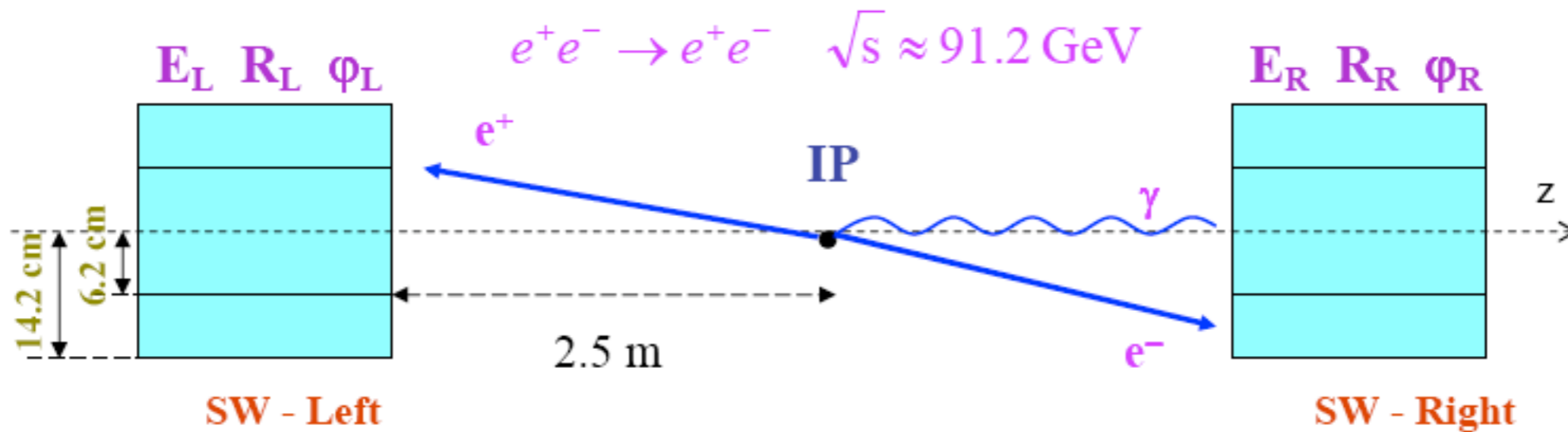

2 cylindrical calorimeters encircling the beam pipe at $\pm 2.5 \text{ m}$ from the Interaction Point

19 Silicon layers Total Depth $22 X_0$
 18 Tungsten layers (14 cm)

Each detector layer divided into 16 overlapping wedges

Sensitive radius: 6.2 – 14.2 cm, corresponding to scattering angle of 25 – 58 mrad from the beam line

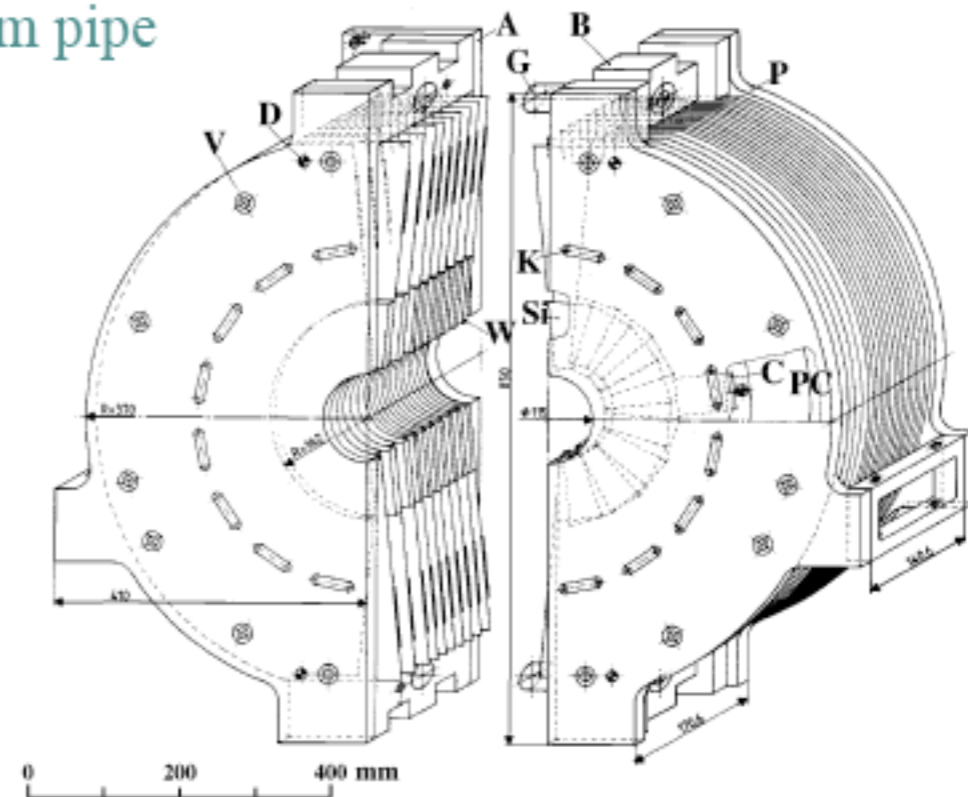

Results

OPAL

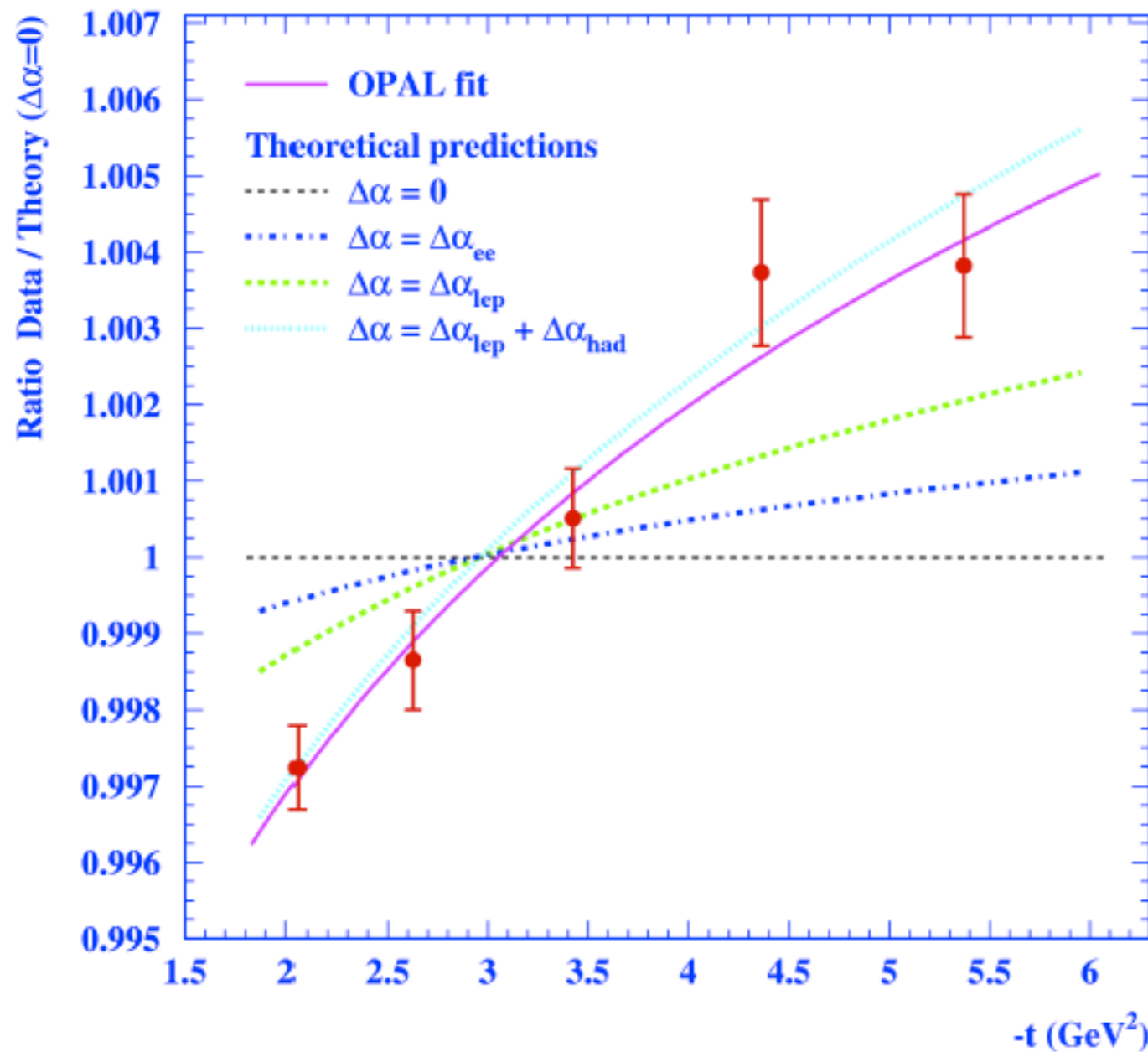

$$\Delta\chi^2 = 0.8$$

$$\chi^2/d.o.f. = 1.9/3 \quad \text{OPAL fit}$$

$$\Delta\chi^2 = 18$$

$$\Delta\chi^2 = 37$$

$$\Delta\chi^2 = 60$$

incompatible

OPAL fit

$$f(t) = \frac{N_{data}(t)}{N_{MC}^0(t)} = a + b \cdot \ln\left(\frac{t}{t_0}\right)$$

$$b = (726 \pm 96 \pm 70) \times 10^{-5}$$

$$\cong 2 \frac{\delta \Delta\alpha}{\delta \ln t}$$



- We propose a novel approach to access directly and to measure the running of α_{QED} in the space-like region .



- It consists in analysing small-angle Bhabha scattering. Depending on the particular angular detector coverage and on the energy of the beams, it allows a sizeable range of the t variable to be covered.



- The feasibility of the method has been put in evidence by the use of a new tool, **SAMBHA** , to calculate the small-angle Bhabha differential cross section with a theoretical accuracy of better than 0.1%.

Conclusions

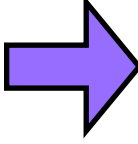

- The information obtained in the t channel can be compared with the existing results of the s channel measurements. This represents a complementary approach, which is direct, transparent and based only on QED interactions and furthermore free of some of the drawbacks inherent in the s channel methods.



- The method outlined can be readily applied to the experiments at LEP and SLC. It can also be exploited by future $e+e-$ colliders as well as by existing lower energy machines.



- An extremely precise measurement of the QED running coupling $\Delta\alpha(t)$ for small values of t may be envisaged with a dedicated luminometer even at low energies. The determination of $\Delta\alpha_{\text{had}}(t)$ is only limited by experimental precision.

